

well-design options. Detailed material evaluations and specifications easily are generated for making comparisons. The program utilizes standard industry engineering methods and calculations for strength evaluations. Wire-wrap screen recommendations are based on the existing guidelines and practices of Johnson Screens North America. Appendix 9.Q (DVD) is a flow chart (from Clear Creek Associates) that provides the various steps in the design and construction of a successful well.

ACKNOWLEDGMENTS

Mr. Ray Schreurs, Johnson Screens, retired, and John H. Schneiders, PhD, President, Water Systems Engineering Inc., provided comments and additions to this chapter. Their insights are appreciated.

CHAPTER 10

Water-Well Construction and Abandonment

Mike Mehmert
Johnson Screens

OVERVIEW OF WELL CONSTRUCTION

A well's construction should be planned so as to utilize every available natural sanitary protection, and should be executed in a manner that avoids any man-made contamination. Key phases of well construction are:

- ♦ Maintenance of borehole integrity during drilling;
- ♦ Installation of casing and screen;
- ♦ Confirmation of screen's exact location;
- ♦ Installation of filter pack (if used);
- ♦ Placement of cement, accurately and effectively;
- ♦ Development; and
- ♦ Disinfection.

Adequate depth and the installation of a surface-grout seal are important to insuring that the well remains free from any contamination caused by surface or near-surface sources. Virtually all high-capacity municipal and industrial wells have surface-grout seals, as do many domestic wells—especially those constructed in rock. Grouting procedures vary depending on the well-drilling and screen-installation methods, as well as by regulatory requirements. They are discussed in detail in this chapter.

Generally, location requirements for high-capacity wells are more restrictive than those for private wells, due to the size of drilling equipment and surface equipment used. Casing depth and grouting criteria usually are established for each individual well prior to installation. If there is any doubt about which well-completion method provides the best protection, then local regulatory agencies should be consulted.

Proper installation of casing and screen is followed by well development and disinfection. Well development—discussed in Chapter 11—is one of the most important parts of well construction. Well disinfection is the final operation completed before placing a well into service. Local regulations often specify minimum mandatory procedures for disinfection. Drilling professionals always should select the construction method that is most compatible with available equipment and local geologic conditions.

INSTALLING CASING

The surface casing is set so that an annulus exists around the permanent casing, which is centered and then is advanced into the formation. As the operation proceeds, the annular space around the permanent casing—in the upper borehole—should be kept about two-thirds full of clay slurry. Some of this slurry is carried downward as the casing advances, and it seals the formation around the pipe. The clay slurry remains viscous as long as it is saturated and a seal is maintained between the advancing casing and the formation, even after the casing is pulled back to expose a screen. The slurry remaining in the annulus between the surface and permanent casing is displaced by grout and the surface casing is removed.

In the southwestern portion of the United States—an area that is dominated by alluvial basins—large-diameter bucket augers are used to drill a borehole for the surface casing for large production wells. For smaller-diameter wells, surface casing can be installed using mud rotary or air rotary drilling methods. These methods can involve borehole stabilization with drilling fluids rather than a casing pull-back.

Casing and Joint Types

When using the direct rotary drilling method, the borehole is filled with fluid during the entire drilling operation. In such overbalanced conditions either multiple (telescope) casing or single-string casing and screen installations are employed.

Using the telescope method, the permanent casing is set and grouted in place using adequate centralizers. After the cement has set, a smaller (or expandable underream) bit drills the borehole below the casing to the appropriate completion depth. In a single-string installation, the screen and casing are fitted with centralizers and placed in the open hole; a filter pack then is installed around the screen. Prior to grouting, fine sand (or fine sand followed by bentonite pellets) or a layer of bentonite is placed on top of the filter pack to prevent the grout from seeping downward. Grout then is installed in the annulus to the surface.

In the field, casing is picked up with special clamps called elevators. Elevators typically slip around the outside diameter of the casing and are closed with a latch or bolt. A pair of elevators is used—while one hoists a single joint into connecting position, the second is resting on the rotary table (or surface casing) supporting the preassembled joints in the borehole. For small-diameter threaded casings, a male-thread hoisting plug combined with a landing-slip receptacle can be used in place of a pair of elevators. The elevator engages the outside diameter upset of a coupling, welded collar, or lifting lugs (*see* Figure 10.1). Well-casing joints are assembled using either welding or mechanical joints. Mechanical joints typically are threads; groove and spline slip-collars, or snap-together locking joints. Each type has benefits and features that facilitate speed, strength, or flexibility, or which address special application needs. Welding (including using solvents to join PVC) is common practice, but the joint then is difficult to disassemble if that need arises. Threaded pipe is more costly, but disassembly—if required—is quicker.

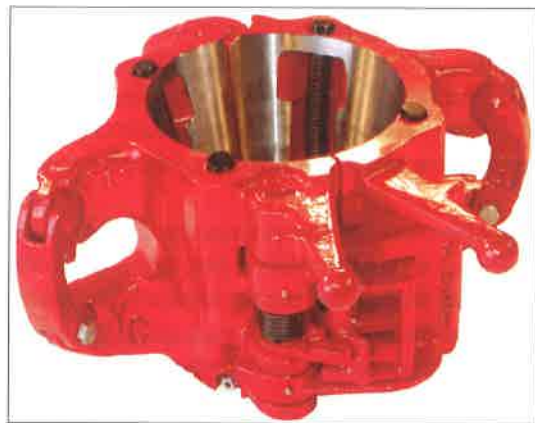

Figure 10.1. Elevator clamp.

More frequently, flush-thread PVC is used along with mechanical joints. If the outside diameter of the pipe remains constant across joints, then pipe typically is raised with a male plug threaded to engage the female-thread end of the casing. The assembly is held vertically in the rig table either by using slips or with a simple tongue-and-groove landing plate (Figure 10.2). An elevator clamp is the recommended means to hold PVC pipe.



Figure 10.2. Landing plate.

Joining Steel Casing

Steel-casing pipe ends that are to be welded should be beveled approximately 30 degrees. The welding should follow standardized procedures (American Welding Society 1981). Casing welds used are fillet, butt, or V-groove. Fillet welds are used to secure lap, corner, and T-joints (common with a slip collar). Weld metal is deposited in a corner formed by the fit-up of the collar shoulder to the pipe wall. Butt welds are circumferential welds around squared pipe ends in the same plane. The degree of penetration is important in determining the quality of a fillet or butt weld.

V-groove welds are used when two squared, beveled pipe ends butt together. The groove should be filled entirely, and this type of weld typically requires multiple passes to complete. Burn-through should be avoided so that metal is not deposited inside the casing—which can hinder or prevent tool movement or screen installation.

Proper selection of electrodes is critical to joining dissimilar metals. Either E 312-16 or E 309-16 (AWS-ASTM classification) electrodes are recommended for joining low-carbon steel to stainless steel. Type E 309 electrodes are readily available and cost less than E 312-16 material. Type E 308-15 or E 308-16 electrodes are used to weld stainless steel to stainless steel. If mild steel electrodes are used to join stainless steel to stainless steel then chromium precipitates, creating areas of low corrosion resistance that eventually leads to structural weakness or failure.

Joining Plastic Casing

Plastic casing can be joined by using either solvent welding or mechanical means. In solvent welding, primer is used to clean and etch the surface before the solvent cement is applied. The solvent is applied uniformly to the casing and the pieces are joined; curing time then is required. Due to flammable vapors emitted by some primers and solvent cements, no welding or other open flames should be allowed near the well head immediately after the PVC joints have been connected.

Low temperatures (less than 40°F (4.4°C)) and poor fit caused by joint interferences are two major problems that affect the integrity of the joint. Drilling professionals must be sure to use the correct solvent cement for each particular casing type and for the specific temperature encountered. In temperatures colder

than 40°F (4.4°C), plastic components should be joined with a low-temperature solvent cement. Additionally, a special solvent must be used when joining PVC and ABS casing due to the different chemical composition of these materials (see ASTM D-3138).

Two types of solvent-welded joints commonly are used. One type uses a coupling (collar) to join casing lengths of equal or unequal diameter, and the ends of the casing fit tightly into the molded plastic coupling. A second type uses a "bell-end" socket that is molded at one end of each casing length to receive the straight (spigot) end of the next casing length. It is important that the bell or coupling be manufactured to close tolerances, so that the fit around the pipe is uniformly snug. See Chapter 9 for solvent-welding procedures. When working at higher temperatures, solvent-cemented joints should be considered under the rating of strength effects for threaded joints.

Plastic casing also can be joined mechanically using threaded couplings or special slip and lock joints (e.g., Johnson Screens Shur-A-Lock™ joint, Figure 10.3). Threaded connections most frequently are used on small-diameter plastic casing (e.g., pump column pipe) and on monitoring wells when joints must be watertight and the use of solvents is not permitted.

For applications performed in conditions where temperatures exceed 110°F (43°C), standard threaded connections should not be used and, instead, special reinforced adapters or optional joint designs should be evaluated for use (and the manufacturers consulted). Special thread lubricants and sealants must be used. Avoid using solvent cement on threads because the cement might set more quickly than the threads can be tightened. Larger-diameter PVC casing is joined by special slip and lock joints, using gaskets to create a seal. Mechanical connections enable disassembly and reuse (if necessary), require no solvents, and save installation time.

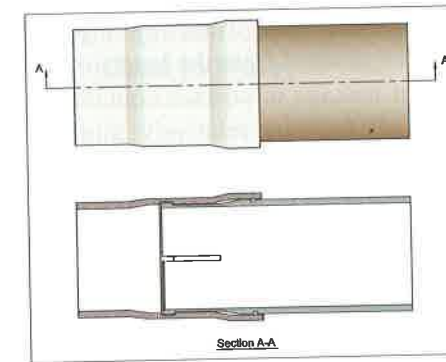

Figure 10.3. Shur-A-Loc™ joint.

Joining Fiberglass Casing

Typically, fiberglass casing is joined using threaded joints because of the extended setting time required when using epoxy or polyester resin cement. In some cases, fiberglass casing is joined by slip joints or by using a flexible key that locks the male and female ends of the casing together. Metallic screens can be adapted for fiberglass casing by the use of threaded adapters. Coupling diameters (see Chapter 9) are large as compared to those of steel couplings. Steel couplings typically add about 1 in (25 mm) to the outside diameter of the pipe and fiberglass couplings add 2 in (51 mm) or more.

GROUTING AND SEALING A WELL CASING

The annulus from the surface to the aquifer typically is filled with grout or some acceptable sealing media. Mechanical seals or grout should be considered for use in the annulus between overlapping casings if the sediments might heave or if the two casings are set in sediments with different static water levels. If the casings are set in clay, then grout use could be unnecessary (unless it is required by local agencies).

Grouting (cementing) a casing involves filling the annular space between the casing and the drilled hole with suitable slurry of cement or bentonite. The length of the borehole section to be grouted varies according to local regulatory

codes, the aquifer structure, and water quality. Typically, all public water-supply wells must be grouted from the land surface to a depth of at least 50 ft (15.2 m), to prevent leakage of surface contaminants. Water wells constructed in rock that is overlain by relatively thin, loosely unconsolidated sediment usually are grouted from the land surface to the rock interface. In some formations where aquifers with poor water quality are interspersed with high-quality water zones, the poor-water-quality aquifers are cemented off. Grouting also is standard practice in monitoring-well construction. It is important to avoid blistering the PVC casing when using a cement grout seal, which can occur due to the heat of hydration while the cement is curing.

The grouting procedures presented below focus primarily on the use of cement and water (neat cement), although in certain uses the slurry can contain sand, bentonite, pozzolan (fly ash), calcium chloride (as an accelerator), or hydrated lime. A slurry made with a high-solids bentonite (granular or chips) also can serve as a grouting seal, provided that it is used at a depth where dehydrating and shrinking of the grout will not occur, and where water movement will not wash away the clay particles. In unique situations (low-pH environments), synthetic polymers can be used as grouting materials.

Various types of portland cement are manufactured to accommodate different chemical and physical conditions. Table 10.1 lists five API cement classes used in water-well construction, although Classes A, B, and C commonly are used. (Cement classifications that are used outside of the United States are provided in Appendix 10.A (DVD). The constituents of these cements are given in API Standard 10A.)

The compressive strengths of portland cement (types A and B) and high-early strength cements (type C) are shown in Table 10.2 for setting times of 24 hr and 72 hr at various temperatures. For most drilling operations, the cement should reach a compressive strength of 500 psi (3,450 kPa) before drilling is resumed. The temperature in the borehole, chemistry of the formation water, dilution of the cement, and downhole pressure affect the rate at which the cement cures. Generally, the 500 psi (3,450 kPa) compressive strength is reached between 12 hr and 24 hr after placement. Equipment for mixing and placing cement grout does not need to be elaborate, however, because the chemical reaction causing hardening begins as soon as cement and water are mixed. The equipment therefore only must be adequate to complete the installation while the grout is fluid.

Table 10.1. Classifications of Cements Used in Water Wells

| API Classification | Special Properties | Recommended Range for Well Depth | |
|---------------------------------------|---|----------------------------------|------------|
| | | ft | m |
| A (similar to ASTM C150, Type I) | None | 0 to 6,000 | 0 to 1,830 |
| B (similar to ASTM C150, Type II) | Moderate to high sulfate resistance | 0 to 6,000 | 0 to 1,830 |
| C (similar to ASTM C150, Type III) | High early strength | 0 to 6,000 | 0 to 1,830 |
| G | Can be used with accelerators and retarders | 0 to 8,000 | 0 to 2,440 |
| H | Can be used with accelerators and retarders | 0 to 8,000 | 0 to 2,440 |

Typically, to achieve the desired result of a uniform sheath of cement around the casing for the vertical distance to be grouted, the borehole diameter should be (at minimum) 4 in (102 mm) larger than the casing. Tight places and “dead spots” result where casing that is not properly centered touches the wall of the hole, and causes channeling of the slurry. Local laws usually dictate the minimum length of grout required for certain types of wells, and drilling professionals should be familiar with these regulations.

Table 10.2. Compressive Strengths of Portland and High Early Cement

| Temperature | | Borehole Pressure | | Typical Compressive Strength* | | | | | | | |
|-------------|------|-------------------|--------|-------------------------------|--------|------------|--------|----------|--------|------------|--------|
| | | | | 24 hr | | | | 72 hr | | | |
| | | | | Portland | | High Early | | Portland | | High Early | |
| °F | °C | psi | kPa | psi | kPa | psi | kPa | psi | kPa | psi | kPa |
| 60 | 15.6 | 0 | 0 | 615 | 4,240 | 780 | 5,380 | 2,870 | 19,790 | 2,535 | 17,480 |
| 80 | 26.7 | 0 | 0 | 1,470 | 10,140 | 1,870 | 12,890 | 4,130 | 28,480 | 3,935 | 27,130 |
| 95 | 35 | 800 | 5,520 | 2,085 | 14,380 | 2,015 | 13,890 | 4,670 | 32,200 | 4,105 | 28,300 |
| 110 | 43.3 | 1,600 | 11,030 | 2,925 | 20,170 | 2,705 | 18,650 | 5,840 | 40,270 | 4,780 | 32,960 |

* Strengths are based on the criteria shown in Table 10.3.

Table 10.3. Compressive Strength Criteria

| | Portland | | High Early | |
|----------------------|----------------------------|---------------------------|----------------------------|---------------------------|
| Water | 5.19 gal/sack | 19.6 l/sack | 6.32 gal/sack | 23.9 l/sack |
| Slurry weight | 15.6 lb/gal | 1,870 kg/m ³ | 14.8 lb/gal | 1,770 kg/m ³ |
| Slurry volume | 1.18 ft ³ /sack | 0.03 m ³ /sack | 1.33 ft ³ /sack | 0.04 m ³ /sack |

(Halliburton 1968; Smith 1976)

Cement grouts exert greater collapse pressure on casing than that exerted by water or drilling fluid. Table 10.4 (below) shows the increase in pressure exerted on casing by cement slurry compared with that exerted by a typical drilling fluid.

Table 10.4. Hydrostatic Loads on Casing

| | Slurry | | Weight | | Pressure Gradient | |
|----------------------------|--------|------|--------------------|-------------------|-------------------|-------|
| | lb/gal | kg/l | lb/ft ³ | kg/m ³ | psi/ft | kPa/m |
| Freshwater | 8.33 | 1.0 | 62.4 | 1,000 | 0.433 | 1.42 |
| Typical Drill Fluid | 9.5 | 1.14 | 71.2 | 1,141 | 0.494 | 1.62 |
| Neat Cement Slurry | 16.0 | 1.9 | 120 | 1,922 | 0.833 | 2.73 |

The potential pressure usually is greatest at the bottom of the casing. For example, the maximum pressure exerted by the cement grout at the bottom of a 500-ft (152-m) casing is 500 multiplied by 0.833, which equals 416 psi (2,868 kPa). A safety factor of 50% is recommended for use when selecting the wall thickness for the casing. Fluid inside the casing reduces the cement column pressure, depending on the relative heights of the fluid and cement columns. If the inside of the casing is dry, then the casing must be strong enough to support the entire grout column.

Cementing Tools and Products

Sometimes referred to as "casing jewelry," cementing tools and products are the mechanical attachments and devices that are incorporated within or onto the casing string to facilitate installation, centering, cementing, and development of the well. Some of the most common devices are described below (see Figure 10.4 through Figure 10.7).

Centralizers

A centralizer (Figure 10.4) is a device that keeps the casing centered in the borehole and away from the borehole walls to facilitate proper cementing. Many types of centralizers are available—from crude shop-made "fins" to specially made commercial varieties. Centralizer devices primarily should not impede installation (hang-up) and should have sufficient centering power (spring steel resistance) to keep the pipe away from the borehole walls. Centralizers also are available with welded and non-welded, high-quality spring steel bows. To prevent galvanic corrosion, centralizers must be composed of the same type of steel that is used for the well casing or screen.

**Figure 10.4. Centralizer.**

Cement Baskets

Cement baskets (Figure 10.5) are designed to protect weak formations from any excessive hydrostatic pressure exerted by the weight of a cement column. These attachments typically are installed on the casing string above the zone to be protected and are used in stage cementing or in cementing the annulus from the surface. The overlapping metal fins provide maximum flexibility and fluid passage while maintaining optimum support characteristics. They should be installed over stop collars to facilitate pipe reciprocation.



Figure 10.5. Cement basket.

Scratchers or Scrapers

Scratchers or scrapers (Figure 10.6) are attached to the casing, and remove excessive wall cake to improve the bond between cement and porous formations. Typically, a series of scratchers is mounted on the casing string.

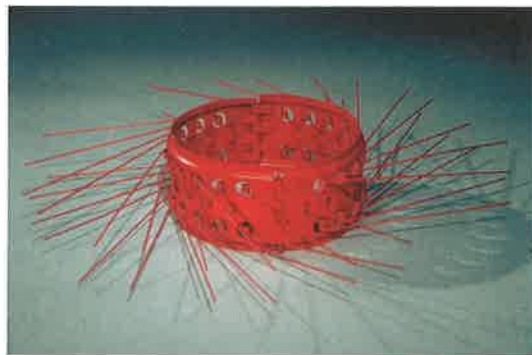

Figure 10.6. Scrapper.

Float Shoes

Float shoes (Figure 10.7) are special end-fittings and contain a drillable check valve. They are attached to the bottom of the casing assembly to provide

buoyancy during installation and to facilitate pumping of the cement from the bottom of the casing assembly (Halliburton method).



Figure 10.7. Float shoes.

Proportioning Cement Grout

Laboratory tests indicate that 5.2 gal (19.7 ℓ) of water are needed to hydrolyze 94 lb or one sack (42.6 kg) of portland cement and produce a slurry weight of 15.6 lb/gal (1,870 kg/m³). The proper water-cement ratio facilitates more effective bridging of cement particles in the pores of permeable formations, preventing excessive penetration. Water is squeezed out of thinner mixtures by pressure against permeable formations—therefore more water means more shrinkage. Cement settles out of the slurry if the amount of water is greater than 10 gal (38 ℓ) per sack, and fluid-loss agents can be used to control such water loss. Water for grouting should be potable and free of oil and other organic material, and its total dissolved solids (TDS) content should be less than 2,000 mg/ℓ (high sulfate content is particularly undesirable).

Bentonite holds cement particles in suspension, reduces shrinkage, and improves the fluidity of the mixture. Approximately 3 lb (1.4 kg) to 5 lb (2.3 kg) of bentonite should be mixed with 6.5 gal (25 ℓ) of water per 94 lb (42.64 kg) of cement. If the amount of bentonite exceeds 6%, excessive

shrinkage occurs. It is best to mix the bentonite and water first and then add cement to the clay-water suspension.

Adding sand or other bulky material helps control fluid-loss conditions but increases the difficulty of handling and placing grout. Additives might be necessary to reduce the cost of the well materials if large openings must be filled. It is important to know the chemical composition of any additives used in grout seals (e.g., fly ash contains trace metals). The physical effect of additives commonly added to the cement is given in Table 10.5.

Table 10.5. Effects of Additives on the Physical Properties of Cement

| | | Bentonite | Diatomaceous Earth | Pozzolan | Sand | Heavy Minerals | Accelerator | Sodium Chloride | Retarder |
|--------------------------|-------------|-----------|--------------------|----------|------|----------------|-------------|-----------------|----------|
| Density | Decreased | ● | ● | ● | | | | | |
| | Increased | | | | ● | ● | | ○ | |
| Water Required | Less | | | | | | | | |
| | More | ● | ● | ○ | ○ | | | | |
| Viscosity | Decreased | | | | | | ○ | ○ | ● |
| | Increased | ○ | ○ | ○ | ○ | ○ | | | |
| Thickening Time Required | Accelerated | | | | | | ● | ● | |
| | Retarded | ○ | ○ | | | | | | ● |
| Early Strength | Decreased | ○ | ○ | ○ | | | | | ● |
| | Increased | | | | | | ● | ● | |
| Final Strength | Decreased | ● | ● | ○ | | ○ | | | |
| | Increased | | | | | | | | ○ |
| Durability | Decreased | ○ | ○ | | | | | | |
| | Increased | | | ● | | | | | |
| Water Loss | Decreased | ● | | | | | | | ○ |
| | Increased | | ○ | | | | | | |

○ Denotes minor effects
● Denotes major effects or principal purpose for which used

(American Petroleum Institute 1959; Smith 1976)

Mixing Grout

Grout should be mixed thoroughly and be free of lumps. If it is purchased from a ready-mix concrete plant, the correct proportions must be insured by the vendor, and the delivery trucks must be cleaned thoroughly before transporting materials to the well site to avoid retaining stones and lumps of concrete. As a final precaution, there should be a protective strainer on the tank from which the grout is pumped.

Portable grouting machines effectively combine both the mixing and pumping operations (Figure 10.8). Most grouting machines are equipped with a positive displacement pump, because effective operation with a centrifugal pump is limited under high-head conditions. Avoid use of the drilling rig's mud pump because cement has abrasive qualities and is difficult to remove completely. Irregularities of the borehole size and losses into fractured rock make it difficult to accurately estimate the volume of grout required, therefore approximately 20% to 30% more than what is calculated always should be included as part of the original mix.



Figure 10.8. Portable grouting machines are capable of performing both the mixing and pumping operations (ChemGrout, Inc.).

Heat is produced and released during hydration (Figure 10.9). The amount of heat released during hydration depends on the volume of cement grout surrounding the casing, the ambient temperature of the formation, and the drilling-fluid pressure in the borehole. The amount of heat is a function of the cement volume (more cement means more heat). If the formation temperature

is high or accelerator additives are used, then the hydration process is accelerated and heat is released more quickly. Cement filling a 2-in (51-mm) annulus produces a maximum temperature rise of 35°F (1.7°C) to 45°F (7.22°C) during hydration (Smith 1976). Heat of hydration is critical in PVC and permafrost installations.

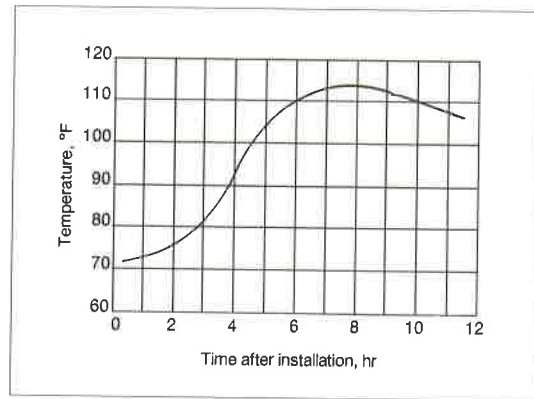

Figure 10.9. Graph showing the temperature change over time at a depth of 550 ft (168 m), where the formation temperature was 65°F (18.3°C), the mixing-water temperature was 74°F (23.3°C), and the slurry weighed 15.4 lb/gal (1,850 kg/m³) (Canadian Institute of Mining and Metallurgy 1965).

Slurry Placement Methods

Successful cement placement depends on the method, the borehole temperature and pressure, and how well the casing is centered. Temperature affects how fast the slurry hydrates (how fast cement strength develops), and pressure (drilling-fluid weight) can reduce the slurry pumping rate. In deep water wells (which have higher temperatures and pressures) the hardening time can be substantially reduced. The use of centralizers every 40 ft (12.19 m) is important to assure a uniform thickness of cement around the casing. The lower end of the casing should be closed with a drillable plug or be driven into clay. If necessary, the buoyant effect of the slurry is overcome by filling the casing with water, drilling mud, or other fluids, or by holding it down with the weight of the drill rig. Using the drill rig can be dangerous if excessive pressures are built up in the

borehole. Several satisfactory placement methods are described below, but it is critical to always insure that channeling does not occur.

To assure a satisfactory seal, grout typically is placed in one continuous operation. When designing the well, hydrostatic loads should be evaluated carefully to prevent structural or formation damage. Regardless of the method used, to minimize contamination or dilution of the slurry or bridging of the mixture, the grout first should be introduced at the bottom. Suitable pumps should be used to force grout into the annular space under turbulent flow conditions, which enhances both drilling fluids removal and the more complete filling of voids. Diaphragm and positive-displacement pumps are used most often to pump cement grout. A positive-displacement pump with an effective output pressure of 250 psi (1,720 kPa) is recommended, but it should not be permitted to pump sand or other abrasives. Diaphragm pumps have lower output pressures (110 psi (758 kPa)), however they can handle particles of up to ¼ in (6.5 mm) to ⅜ in (9.5 mm) in diameter. Both pump types are used for batch mixing.

For larger grouting jobs, use of either positive-displacement pumps or (less frequently) centrifugal pumps is favored. Positive-displacement pumps (2 x 3, 3 x 4, or 5 x 6) can build pressures to 250 psi (1,720 kPa), and have been used successfully to place grout to 3,000 ft (914 m) or deeper via a 2-in (51-mm) tremie pipe. Because they develop less pressure, centrifugal pumps can be arranged so that a hopper feeds the pump under pressure, thereby increasing pump output.

If an open borehole is drilled below the casing depth, the hole must be backfilled or a bridge (cement basket or formation packer shoe) be set to retain the slurry at the desired depth. Backfilling with clean fine sand is a common procedure used to prevent cement from penetrating downward more than a few inches. If the borehole cannot be backfilled, then external packers with float shoes are used to support the cement column. Cement baskets are clamped on the outside of the casing (Figure 10.10). External packers are installed in the casing string (Figure 10.11) and then expanded before cementing begins.



Figure 10.10. Cement basket.



Figure 10.11. An external packer equipped with a float shoe can be installed in the casing string to facilitate placing cement grout.

Cement always should be allowed to adequately harden (typically for 24 hr) before drilling resumes, therefore “waiting on cement” (W.O.C.) time should be included in the well-construction procedures and schedules. It is unwise to risk damaging a good grouting job by drilling the plug too soon.

Tremie Pipe Located Outside Casing

A string of small-diameter pipe, called tremie pipe or grout pipe, is placed outside of the casing (Figure 10.12). The casing is lowered with centering guides attached. If the tremie is set separately, the centering guides must be aligned

along the entire length of casing that is to be grouted. Grout can be placed using gravity, but pumping is preferred because the required volume can be introduced rapidly and with less chance of voids occurring within the grout. The bottom of the tremie always should be submerged a few feet beneath the grout level. Pump pressure must equal or exceed the hydrostatic pressure of the grout plus the fluid friction in the grout pipe and annular space.

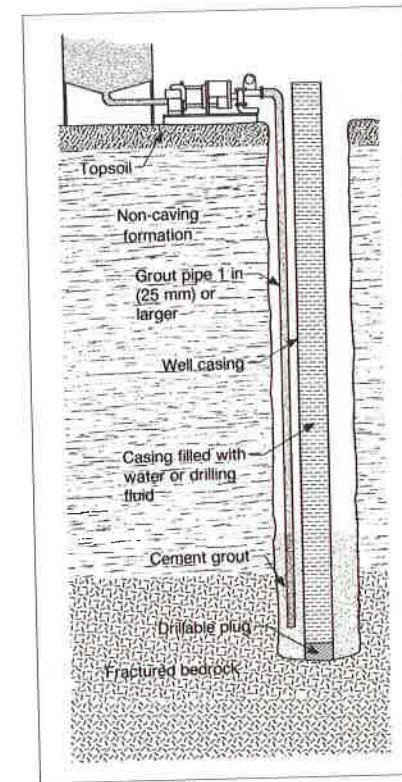

Figure 10.12. Illustration of grouting using a tremie pipe suspended in the annulus outside the casing.

In shallow holes, the cementing operation is completed in a single step (if a positive-displacement pump with adequate pressure is used) and the tremie pipe is not moved as the annulus fills. If a centrifugal pump is used, or if the

hole is deep, the tremie must be raised periodically to keep the hydraulic head below the working pressure of the pump. Usually the tremie is withdrawn (one or more joints at a time), but the bottom always should remain beneath the surface of the cement. The depth to the top of the grout can be detected by using a weighted line or a weight indicator, or by estimating the volume of material that the hopper contains before grouting begins as compared to unit volume in the annulus.

The grout pipe must be large enough for grout to be placed before hardening begins. A 3/4-in (19-mm) or 1-in (25-mm) pipe can be used, although 2-in (51-mm) pipe is used for deeper holes. To accommodate the pipe, the borehole should be 4 in (102 mm) to 8 in (203 mm) larger than the casing. If the tremie pipe becomes plugged, then it should be raised above the grout level and not be lowered back into the slurry until all of the air and water inside the pipe have been displaced by grout.

When multiple filter-pack screens are separated by grouted casing sections, a larger-diameter hole is drilled and slurry usually is placed using a tremie that is outside of the casing. The top of the filter pack is at least several feet above the top of the screen, and the grout is run up slightly higher than the formation to be isolated. Low-permeability sand is placed on top of the filter pack to contain the grout until it hardens (Figure 10.13).

An alternative is to use a layer of coated bentonite pellets. Once the lower grout has set, additional filter-pack material is introduced for the next screen, followed by another layer of low-permeability sand, and then another grouted section (if necessary).

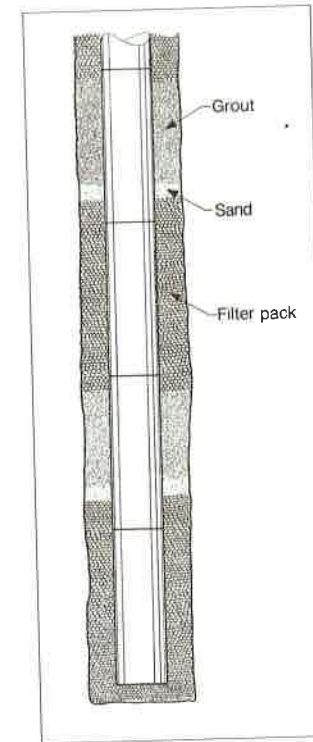

Figure 10.13. Sand sometimes is placed on top of the filter pack to prevent grout from penetrating the pack.

Tremie Pipe Located Inside Casing (Inner-String Method)

If using a grout pipe outside the casing is impractical, then pipe temporarily is installed inside the casing (Figure 10.14). This often is referred to as the inner-string method. Before the casing is placed in the borehole, a float shoe is attached to the bottom of the casing. A tremie pipe then is suspended inside the casing and lowered until it engages the shoe. The float shoe permits the grout to pass into the annular space but prevents backflow into the casing (Figure 10.15). All the internal parts (e.g., valve, spring) can be drilled out easily upon completion of the cementing.

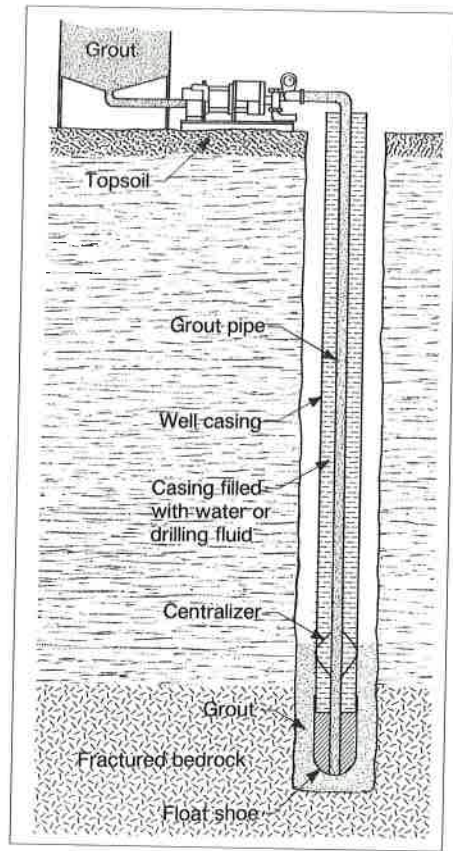

Figure 10.14. Illustration of the inner-string method for placing grout.

The casing is filled with water and suspended just off the borehole's bottom. Grout is pumped through the grout pipe and float shoe, and moves upward around the outside of the casing. When cement appears at the surface, but before the grout pipe is pulled out to displace any remaining slurry, the pipe is disconnected from the float shoe and flushed with water. After completing the cementing operation, the casing is completely flushed with clean water to prevent drilling-fluid contamination. A braden head also can be used for the prevention of casing collapse during cementing.



Figure 10.15. A cementing shoe has a ball-type check valve that prevents the grout from reentering the casing when the tremie pipe is withdrawn.

Casing Method

Adopted from oilfield well-completion methods, the casing grouting method involves pumping grout down the well casing, out the base of the casing or float shoe, and into the annular space. Two spacer-plugs (wiper plugs) are used, the first separates the cement slurry from the drilling fluid in the casing, and the second separates the slurry from the water pumped behind to wash the slurry from the casing (originally called the Halliburton method, Figure 10.16). Spacer-plugs should be made of drillable materials; wood and rubber often are used.

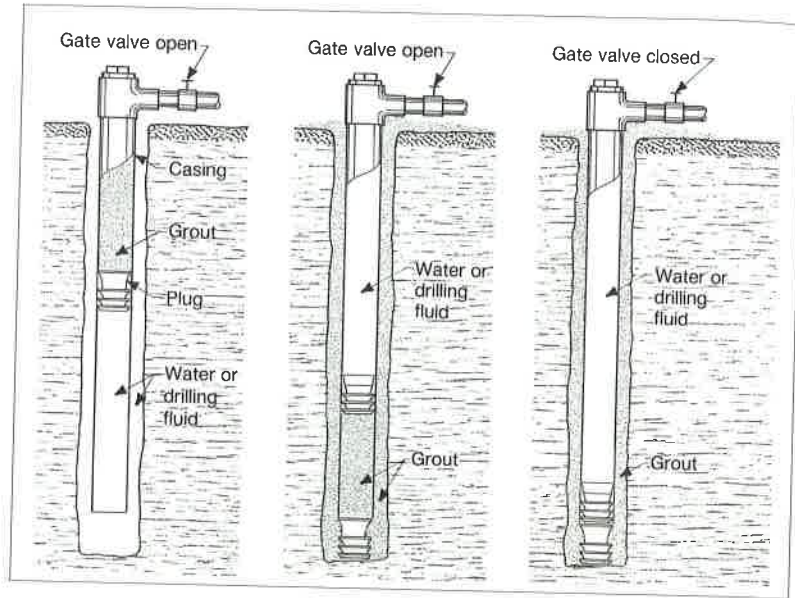

Figure 10.16. Grout can be placed into the casing and then forced out of the bottom and up the annulus. Plugs are used to separate the grout from the drilling fluid and water is used to drive the grout into place.

In the casing method, water or drilling fluid is circulated through the annular space to clear obstructions, the first plug is inserted, the casing is closed with a head manifold, and then a measured volume of grout is pumped. A second wiper plug is released from inside the manifold and a measured volume of water is pumped, pushing the second plug to the bottom and forcing most of the cement slurry from the casing into the annular space. The manifold is closed, holding the water in the casing under pressure to prevent backflow. After the cement has hardened, the plugs and any remaining cement in the casing are drilled out. Drilling can continue into the formation, or the drilling fluid can be conditioned or replaced (if contaminated by residual cement). It occasionally is necessary to remove residual cement scale from casing walls using brushes or scrapers.

An optional single-plug procedure includes pumping a predetermined quantity of grout directly into the drilling fluid-filled casing. A plug then is inserted and enough water is pumped into the casing to force all but 10 ft (3 m) to 15 ft (4.6 m) of grout from the casing. To achieve an uncontaminated, uniform seal, the initial slurry—now diluted by the drilling fluid—must be expelled

to the surface as waste. The plug insures that slurry and water remain separate, for creation of a proper seal at the bottom of the casing.

To eliminate over-displacement or under-displacement of the cement, a landing collar is set 10 ft (3 m) to 20 ft (6.1 m) above the bottom of the casing, and this stops the drillable plug at the appropriate depth. To avoid damaging the bottom of the casing by exerting excessive pump pressure after the plugs have come together, a wire line sometimes is attached to the upper plug so that depth can be measured accurately.

Sometimes the borehole must be grouted after installation of the casing and screen. A single string of screen and casing that must have grout above the screen requires cement baskets for isolating the screen from the annulus. The cement baskets (the use of two or more is preferable) are attached above the screen during installation and a drillable bridge plug is placed in the casing above the screen. Holes are cut into the casing above this plug by a mills knife or other kind of perforator, and cement slurry is pumped into the casing and forced into the annular space above the cement basket (Figure 10.17). Grout usually is extended 5 ft (1.5 m) above and below the formation to be sealed. This method should not be used where zones containing poor-quality water must be sealed off in multiple-screen installations.

Installing Bentonite Grout

Bentonite grout has several advantages over cement grout: It has a faster setting time, does not experience the heat of hydration, has lower hydrostatic pressure (specific gravity is 9.2 for the grout given in Table 10.6), and costs much less than cement. Bentonite also adheres to both walls of the annulus; cement adheres firmly only to the soil. It swells rather than shrinks over time, and bentonite essentially is chemically inert.

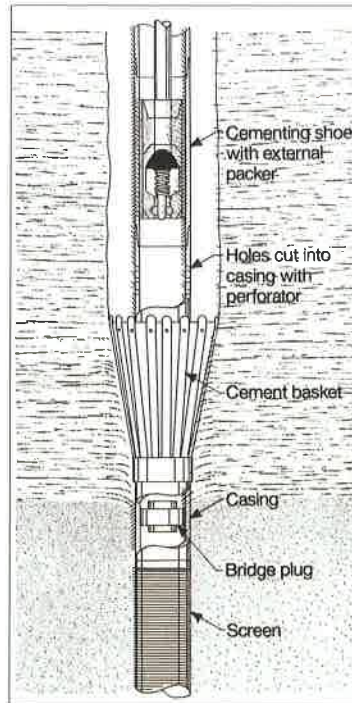

Figure 10.17. A cementing shoe directs the grout out into the annulus above cement baskets mounted in the casing string.

Table 10.6. Amounts of Bentonite, Water, and Polymer Required to Grout 100 ft (305 m) of Three Common Borehole Diameters

| Pipe Size/Borehole Diameter | Bentonite | | Water | | Polymer* | |
|---|-----------|-----|-------|-----|----------|-----|
| | lb | kg | gal | ℓ | qt | ℓ |
| 2-in (51-mm) pipe / 4-in (102-mm) hole | 75 | 34 | 50 | 189 | 0.5 | 0.5 |
| 4-in (102-mm) pipe / 6-in (152-mm) hole | 112 | 51 | 75 | 284 | 0.75 | 0.7 |
| 5-in (127-mm) pipe / 8-in (203-mm) hole | 225 | 102 | 150 | 568 | 1.5 | 1.4 |

* Concentration of polymer recommended for EZ mud.

Bentonite is widely used as a grouting material. Due to its low cost and ease of placement, it is especially applicable for monitoring wells and water wells where surface contamination could occur. Commercial bentonite that is used for grouting is available in either pellet, granular, or chip form. When mixed with water bentonite begins to hydrate immediately, thus making it difficult to place the granular form by dropping the particles into the annulus. Even pellets begin to stick together or adhere to the walls of the annulus within only a few feet of the surface—bridging high above the intended depth. Freezing the pellets allows them to settle a greater distance before they begin sticking. It is recommended that the pellets be tamped into place to eliminate any bridging; however this might not be possible given the depth of placement.

A much better practice when grouting with bentonite is to use a tremie pipe to pump a prepared bentonite slurry that is limited to 20% to 30% solids. A mixture of only 1 lb (0.5 kg) of bentonite granules per 1 gal (3.8 ℓ) of water results in viscosity near the limit of pumping capacity. Even though the ground around the grout usually remains somewhat moist, grout with this concentration of bentonite eventually might shrink up to 25%—an unsatisfactory shrinkage rate. Virtually no shrinkage occurs when mixing 1.5 lb (0.7 kg) bentonite per 1 gal (3.8 ℓ) of water, but this concentration can be pumped only if the water is pretreated with 1 qt (0.9 ℓ) of polymer per 100 gal (380 ℓ) of water. The polymer prevents clays from hydrating immediately, and once properly mixed the viscosity remains low enough to pump for about 20 min. Mixing should be done using a paddle and not a mixer—which breaks up the particles causing the viscosity to increase prematurely. Bentonite grouts therefore are best mixed in batches.

The diameter of the suction hose on the grout pump should be as large as possible and, to make the pump operate more efficiently, the slurry reservoir should be above the pump intake. The pump and all piping should be flushed with clean water after each batch of grout is pumped into place. The volumes of bentonite, polymer, and water for various annulus sizes (per 100 ft (30.5 m) of depth) are given in Table 10.6 (above). Other bentonite grout limitations are listed below.

- ◆ Bentonite should not be used above underreamed boreholes because the “set” might not be sufficient to withstand the vertical pressures.
- ◆ Bentonite should not extend so close to ground surface that it dries out and shrinks due to low soil moisture.

- ◆ Saltwater causes bentonite grout to flocculate and lose viscosity.
- ◆ Acids (organic and inorganic) can destroy the impervious character of the grout seal.

Grouting Failures

Several factors can contribute to grouting failures, including premature setting, partial setting, insufficient grout-column length, voids or gaps in the grout, excessive shrinkage, and casing collapse. Premature setting can be a serious problem and usually is caused by incorrect assumptions concerning borehole temperature, use of hot mixing water, improper water-to-cement ratios, contaminated mixing water, mechanical failures, and interruption of the pumping operation. Voids within the grouted annulus usually are caused by the casing coming into contact with the borehole wall or by the presence of washouts. Careful planning of any grouting job is important.

TESTING THE GROUT SEAL

Prior to drilling the grout plug the effectiveness of the seal can be checked using three methods: measuring the water-level change inside the casing over time; pressure testing; and analysis of an acoustic (sonic) cement-bond log (*see* Chapter 4). In areas where there is a low static-water level relative to the depth of the well, the casing can be filled with water or drilling fluid and later checked for fluid loss. A loss is indicative of leakage in the grout seal. If the static-water level is high outside of the casing, then the fluid level in the casing can be lowered and any influx of water can be measured. This procedure, however, should not be used with thin-walled casing. When using pressure testing the grout must be able to contain pressures of 7 psi (48.3 kPa) to 10 psi (69 kPa) after curing for at least 1 hr. If acoustic logging is used, then it must show that no voids or gaps exist in the grouted annular space.

Abandoned and improperly constructed wells provide vertical openings or channels through which contaminated water can enter usable freshwater aquifers. Regardless of the grouting technique, a more complete seal is attained if the grout slurry is placed in a turbulent manner.

INSTALLING WELL SCREEN

Many different screen installation methods exist. Certain procedures are more practical or more economical, and the choice of installation method depends on the nature and hydraulic conditions of the aquifer, the drilling method used, the borehole dimensions, and the selection of casing and screen materials. The most common and most successful installation methods are described below.

Setting Screen in Rotary-Drilled Wells

The pull-back method is used in cases of extreme caving or lost circulation, when the drilling fluid is unable to control borehole problems adequately. The exceptions are:

- ◆ When drilling in relatively shallow, unconsolidated sediments where natural compaction is not great;
- ◆ When drilling in confined aquifers where the material is close to a condition where any suction or other disturbance in the borehole causes the sediment to “run” toward low-pressure;
- ◆ If a delay is anticipated between drilling and screen installation; or
- ◆ If a casing-advance drilling method, such as cable tool or dual rotary, is used in an unconsolidated or unstable formation.

Air-rotary tools equipped with casing drivers typically sink the casing to the top of a clay layer under the aquifer, insert the screen, and then pull back the casing. If no clay exists and heaving is a problem, then it might be necessary to change from air-based to water-based drilling fluids to control pressures in the formation so that the screen can be set. Occasionally stiff foam is sufficient to control the formation.

Double-String Installation

A typical procedure for installing screens in high-capacity wells includes the following steps.

- ◆ Drill a small-diameter test hole, keep a detailed geologic drill log, and collect geologic samples.

- ◆ Log the test hole using geophysical methods (typically including SP, resistivity, natural gamma, and caliper measurements). Including side-wall or standard cores is optional.
- ◆ Collect water samples from a temporary well or drill-stem test (if water-quality data is required).
- ◆ Analyze test-hole data and make final design decisions.
- ◆ The test hole often is used as a pilot hole and is enlarged (reamed) for the installation of the production screen. The test hole also can be completed as an observation well, temporarily providing make-up water for drilling the production well.
- ◆ The borehole is drilled to the top of the aquifer (Figure 10.18).

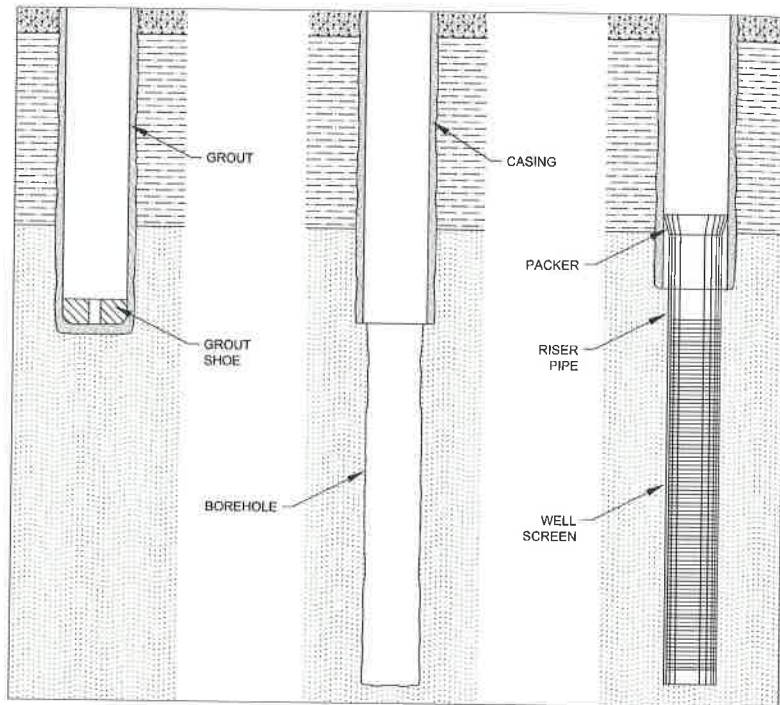

Figure 10.18. A well screen can be set in an open borehole that is drilled below the well casing after the casing has been grouted.

- ◆ The casing generally is set with a drillable or “stab-in” grout (float) shoe (made of cast aluminum or cement) on the bottom, which allows grout to be pumped through the bottom of the casing (the best way to insure proper centering).
- ◆ The casing is grouted and allowed to set for at least 24 hr.
- ◆ The grout shoe and excess grout are drilled out and the drilling fluid is replaced before beginning any drilling into the aquifer. These steps keep grout from entering the aquifer and prevent drilling fluid contamination.
- ◆ The aquifer is drilled (or underreamed) according to the design diameter for either a natural or filter-pack completion.
- ◆ A suitable length of riser pipe is attached to the top of the screen. If there will be blank pipe between the top of the screen and the bottom of the casing and the well is filter packed, then include a 5-ft (1.5-m) length of pressure-relief screen in the riser pipe string and set it at the bottom of the casing (pressure-relief screens are discussed in Chapter 9).
- ◆ The screen assembly is attached to the top of the riser pipe and telescoped into the open borehole connected to the bottom of the drill-pipe assembly. In deep holes, a longer drill-pipe assembly can exert high loads on back-off threads, and should be held in tension while disengaging. If the well is to be filter packed, then at least one centralizer is attached near the bottom of the screen and another attached near the top (Figure 10.19). Centralizers for screen lengths of less than 200 ft (61 m) are spaced every 20 ft (6.1 m); or (for economic reasons) every at 40 ft (12.2 m) on screen intervals of more than 200 ft (61 m).
- ◆ If borehole sloughing or fill requires washing the screen into place, then mount a self-closing wash plug with internal left-hand threads in the screen bottom. A wash pipe attached to this fitting can be used either to set the screen or to displace drilling fluid from the borehole, thus aiding development.



Figure 10.19. Centralizer on a screen (Clear Creek Associates).

- ♦ For a naturally developed well completion, the formation around the screen is induced to collapse by lowering the hydrostatic pressure in the well, or by thinning the drilling fluid or lowering its level in the borehole. The setting tool is removed and development begins. Shale catchers (traps) and formation packers sometimes are used to prevent sloughing of overlying materials (especially clays) when a well is naturally developed. If the well is gravel packed, then the setting tools remain in place during packing and are removed when development is started. Once the well is developed, a packer or grout seal can be installed to provide a seal between the riser pipe and casing. Normally no packer is required if the riser pipe extends 50 ft (15m) or more into the casing.

Single-String Installation

In most deep wells the screens are attached directly to the bottom of the casing. A long assembly of casing and screen is flexible with a high ratio of length relative to its diameter, and little column strength. A string that is 200 ft (61 m) long and 12 in (305 mm) in diameter has a length to diameter ratio of 200 to 1 (similar

to 12 in (305 mm) of 1/16-in (1.5-mm) wire). It always is best to suspend the string from the surface during installation without resting the column on the well bottom. Once lateral support is attained—either by gravel packing or collapsing the formation in a naturally developed well—the column safely can be released. Failure to observe this precaution, however, might result in a collapsed or crooked well. Centralizers are extremely effective in maintaining proper alignment and are recommended for all screens that are more than 20 ft (6.1 m) long.

If the screen diameter is smaller than the casing, then a cone adaptor is used (Figure 10.20). The casing and screen are set and the drilling fluid is thinned. Drilling fluid not properly thinned can remain outside of the screen, creating differential pressures between the screen and the formation—pressures potentially sufficient to collapse the screen or casing. One way to prevent this situation is to fill the casing and screen with drilling fluid or water. The drilling fluid must be in proper condition (e.g., thinned).

For naturally developed wells, the formation is induced to cave around the screen interval immediately after the screen is set. For gravel-packed completions the filter-pack material is placed before formation caving is induced. To prevent silts and clays that are above the aquifer from sloughing during natural development, sometimes a formation stabilizer is installed (Figure 10.20) to hold these materials in place until the formation caves against the stabilizer. (The size gradation of a stabilizer is discussed in Chapter 9). In most cases, a formation stabilizer is not needed if the borehole is only slightly larger than the screen and the top of the screen is placed 3 ft (0.9 m) or more below any clay zone. To prevent sloughing, shale catchers (or cement baskets) also can be mounted on the casing in place of a stabilizer.

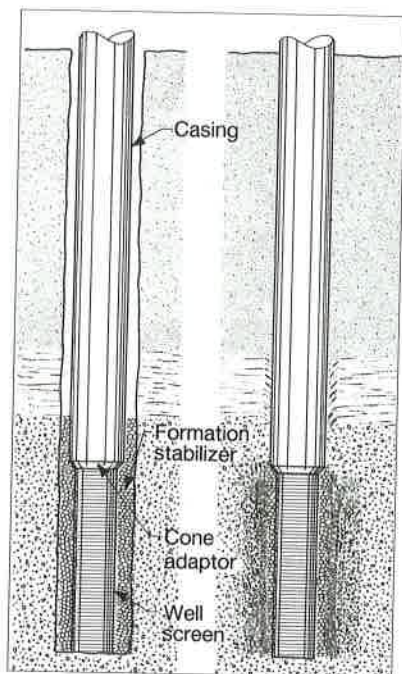

Figure 10.20. Illustration of how a formation stabilizer prevents sloughing against the well screen from formations above.

Packer Use in Screen Installation

A packer could be required to prevent sediment from entering the space between the two overlapping assemblies. Two types of packers can be attached to the top of the screen: a static packer or a mechanical packer. A simple static packer (also called a K-packer) typically is a ring made of neoprene rubber that is attached to a long weld-ring above the screen. A mechanical packer expands once in place. Both types are attached directly to the top of the well screen or the riser pipe.

K-Packer

A flexible neoprene K-packer is attached to a steel ring or coupling and fits tightly in the casing, sealing the casing to the screen (Figure 10.21). This type of packer is popular because no expansion is required. It is recommended that two or more K-packers be used in series to compensate for small deviations in well-casing dimensions, weld-slag protruding inside the casing, damage from improper handling, or for screens set to depths exceeding 300 ft (91.5 m).



Figure 10.21. Self-sealing neoprene rubber packers (K-packers) form an effective seal between the casing and upper end of the screen or riser pipe.

Liner Hanger

Liner hangers (Figure 10.22) often are used in deep wells and are more expensive than K-packers. One type of expandable packer uses a sliding mandrel to expand a hollow rubber cylinder. The packer ordinarily is attached to a riser pipe and is expanded in the casing. The top of the packer is fitted with a left-hand thread and enables the drillpipe to be disengaged. A sliding-end packer has a smaller expansion ratio than does an inflatable packer.

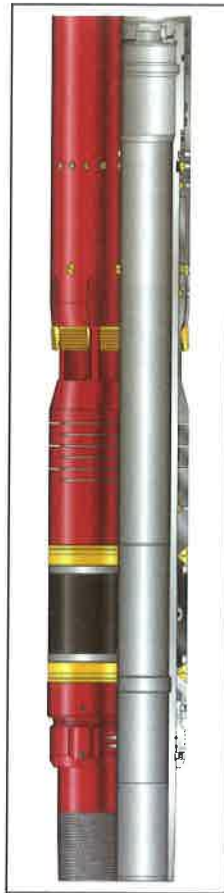

Figure 10.22. Liner hanger.

Inflatable packers (Figure 10.23) generally have larger expansion ratios than do casing hangers. The packer is inflated by injecting gas, water, or a solidifying liquid. Inflatable packers can be used for a short time and then retrieved or can be installed permanently. Some fixed-end packers can be inflated to two times the uninflated diameter or more, but they generally are designed for lower-pressure applications than are sliding-end packers. Sliding-end packers are used where the differential pressures range from 200 psi (1,380 kPa) to 2,000 psi (13,800 kPa) or more, or where high expansions are required.



Figure 10.23. Inflatable packers are used as permanent or temporary sealing devices to isolate portions of the wellbore (Baski Inc.).

Installing Prepack Screens—Muni-Pak™

When a filter pack is desired, the many practical and economic advantages offered by prepack screens should be considered. Prepack screens are ideally suited for horizontal wells, deviated wells, and wells having conventional vertical orientations. Borehole diameter requirements typically are less than what is needed for conventional filter packing and equipment, and the logistics necessary to receive, handle, and place filter pack onsite are eliminated—saving additional time and costs. Typically the recommended borehole diameter for a Muni-Pak™ screen is 2 in (50 mm) to 4 in (102 mm) larger than the Muni-Pak™ outside diameter.

The outside diameter of the Muni-Pak™ screen assembly is larger than the connections, thus extended connections are standard. Individual screen lengths of up to 40 ft (12 m) are available. Muni-Pak™ screens have 4 to 6 times the design collapse strength and approximately 3 times the design tensile strength of conventional rod-based screens. Procedures for setting Muni-Pak™ screens are the same as for conventional screens.

Collapsing the formation around Muni-Pak™ is the ideal first step in development. When a Muni-Pak™ screen is installed as a single string with the casing, shale traps or cement baskets should be attached above the screen zone

to prevent premature sloughing of shallow, unstable fine-grained lenses, particularly if the borehole drilled is “oversized” to allow for cementing through a tremie or grout pipe.

Muni-Pak™ uses hydraulically efficient carbolite™ with a filter thickness approximately one-half that of a conventional gravel pack, therefore it is easier to develop. Placing a formation stabilizer outside the Muni-Pak™ is not recommended. As with other screen installations, before aggressive development is initiated, flow through the screen should be established. Muni-Pak™ screens are suited for both telescoping and single-string completions.

Installing Polyvinyl Chloride Screens

Polyvinyl chloride (PVC) materials have predictable physical limitations but—when properly selected and handled—they provide wells with adequate strength, good hydraulic characteristics, and long life. For depth settings exceeding 300 ft (91.5 m), contact the screen manufacturer for recommendations.

Installation of screens made from PVC is similar to installation of steel screens but, because a PVC screen’s strength is much less than that of steel, PVC screens require different handling. Johnson Screens custom collared elevator and grooved pipe greatly facilitate handling large-diameter PVC (Figure 10.24). Figure 10.25 is a photograph of a PVC joint in an elevator. Additionally, PVC casing can be buoyant when placed in the borehole, so setting procedures might require modification. Today, more hybrid wells (which have plastic casing and stainless steel screens) are installed using both the telescope and the direct-attached well-completion methods.

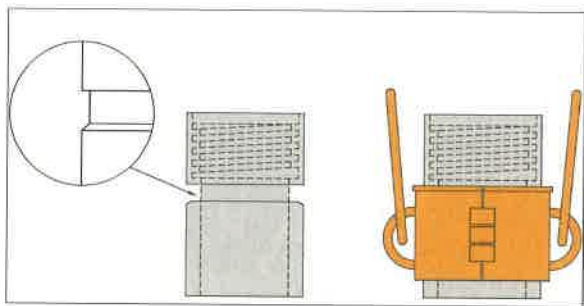

Figure 10.24. Collared elevator and grooved pipe.



Figure 10.25. Elevator holding PVC pipe.

The most common PVC casing used in wells is made to meet Schedule 40, 80, or SDR-21 specifications. A wide variety of end fittings is available to fit any size PVC screen on the market, and includes male adaptors, female adaptors, reducers, and slip couplings.

Plastic screens are attached directly to casing using solvent-weld couplings or mechanical connections (e.g., flush or standard threads, spline couplings on slip-lock fittings such as the Shur-A-Lock™ design). After placement the screen can be filter packed and the annular space sealed, commonly with bentonite grouts. Placement of the pack and backfill material should be completed carefully, because the collapse resistance of PVC is less than that of steel casing. If no filter pack is used, then a rubber shale trap often is fastened to the casing above the top of the screen and backfilled with a small amount of clean clay material. Bentonite can be placed in the annulus above the fill material. PVC can be grouted in place with neat cement, however the curing temperature of the cement must not be so high that the casing deforms. For this reason, exercise caution when using cement grout to seal the annulus of a PVC-cased well in formations that might be prone to borehole washouts.

Stainless steel and PVC vee wire screens often are telescoped through steel and PVC casing via a K-packer. The varying inside diameter (depending on schedule or SDR number) can cause problems with packer fit, therefore consulting the manufacturer can prevent the potential for sand problems.

During development, differential hydrostatic pressures exerted on both the casing and the screen must be minimized. Development should be done gently, until all drilling fluid is removed from the annulus around the screen and water is flowing freely into the screen. The casing and screen never should be “blown dry” with an air compressor. If compressed air is used for development, then start the development process well above the screen and at first remove only small quantities of water. Additional details regarding development are provided in Chapter 11.

Wash-Down Installation Methods

There are two common wash-down installation procedures. One method is used for installing well screens through casing. The wash-down bottom tool with a spring-loaded (or float ball) valve permits the washing of a screen into place, and space around the packer allows return flow outside the well screen (Figure 10.26).

The casing first is set and grouted, and then the cement plug is drilled out. A string of pipe (usually drillpipe) is used as the wash line; this is threaded into the self-closing bottom with a left-hand thread. Water or lightweight drill fluid then is pumped through the line with adequate volume and pressure to produce a jetting action to loosen and remove sediment, thus allowing the screen to sink with no rotation. The sediment washes up around the screen and inside the casing. As velocity decreases above the packer, some larger particles drop inside the screen. Excessive sediment buildup in the screen could sand lock the wash line which makes it difficult to disconnect and remove.

When the screen reaches bottom, clean water should be circulated to remove fines and collapse the formation around the screen. In general, the same wash-down procedure is used in an open hole. Sloughing might occur and grip the screen, or the casing and screen can be placed just above the aquifer and washed into place. This method commonly is used in the United States for completing coal-bed methane wells, where a pilot hole is drilled before the screen is washed into place.

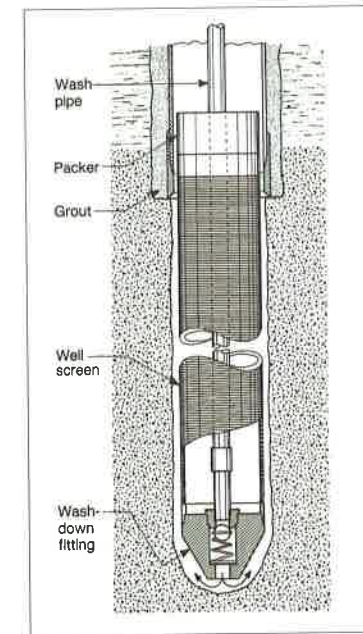

Figure 10.26. A wash-down bottom tool with spring-loaded valve.

A second wash-down method for installing small-diameter screens (usually 2 in (51 mm)) is to use a temporary wash pipe inside of the well screen before the screen is attached to the bottom joint of the casing. The wash pipe (commonly $\frac{3}{4}$ in (19 mm)) extends 1 ft (0.3 m) to 2 ft (0.6 m) into the casing (Figure 10.27), or to the surface if the well depth is not great. A coupling screwed to the lower end of the wash pipe rests in a conical seat in the self-closing wash-down fitting (equipped with a plastic-ball closure). A semi-rigid plastic ring seal (doughnut) is slipped over the upper end of the wash pipe and pushed into the top of the well screen, closing the space around the wash pipe directing the jetting water into the pipe. If the wash pipe extends to the surface, the ring seal prevents return flow of jetting water to the space between the wash pipe and the screen. All return flow takes place outside of the screen and casing.

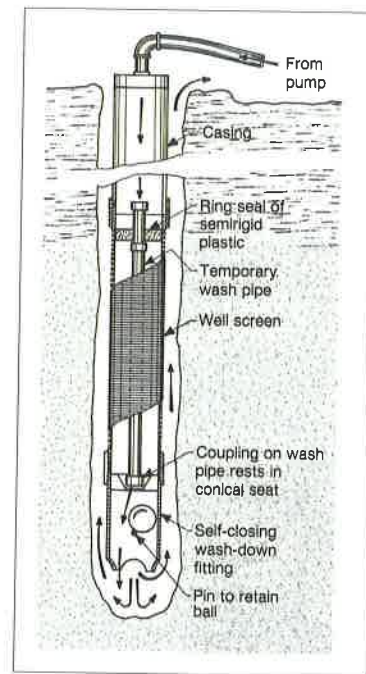

Figure 10.27. Illustration of a temporary wash pipe inside the well screen, used to wash small-diameter screens into place.

When jetting with water, screens can be installed efficiently to depths of approximately 50 ft (15 m) or less, due to fluid loss and caving when a casing is added. To achieve greater depths, a drilling-fluid additive must be mixed with the jetting water. About 5% of the jetting water leaks from around the bottom wash pipe and out through the screen, which helps prevent fine sand from entering during the jetting operation and reduces the possibility of sand locking the wash pipe inside of the screen.

When the well screen has been set at the proper depth, the wash pipe is removed and the well is developed. In some cases, screens can be set without the wash pipe and seal, however significantly larger volumes of water are required because some water escapes through the sides of the screen and does not aid the jetting action occurring at the bottom of the screen.

Installing Well Points

Well points typically are installed using some of the same methods described above, as well as via the pull-back method or by driving beyond the end of casing. Figure 10.28 illustrates a well-point installation completed by pulling back the casing and causing weight to be placed on the well point. Many 2-in (51-mm) stainless-steel well points are installed in 4-in (102-mm) wells by use of this method. Small 2-in (51-mm) well points are set easily through hollow-stem augers, where the string is lowered inside the auger to the bottom of the borehole and the auger flight then is retrieved. This method is particularly suitable for use in shallow, unconsolidated, or caving formations, and for installing monitoring wells. See Chapter 3 for additional information on the auger method.

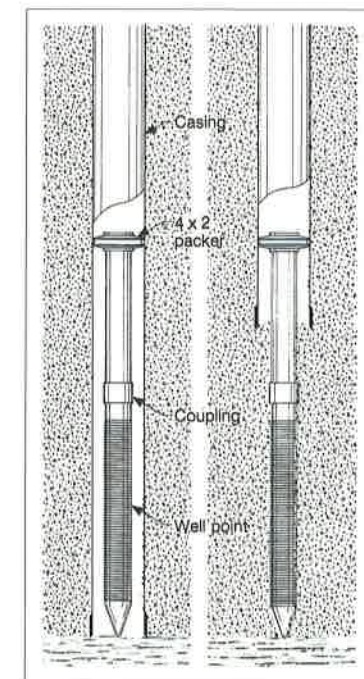

Figure 10.28. Two-inch (51-mm) well points can be set in 4-in (102-mm) diameter wells via the pull-back method.

Before driving a well point, all the sediment in the casing is removed to prevent sand locking. If there is a chance that the sediments might heave, the casing should be kept full of water while the point is set. A K-packer is attached to the top of the well point and is placed through the casing. A driving bar, drill stem, or other tool is raised and lowered to drive the well point through the bottom of the casing. To minimize potential damage to the screen, using a weight that is less than 250 lb (113 kg) together with a 2-ft (0.6-m) stroke is recommended. Careful measurements must be made so that the drilling professional knows when the screen has been driven the correct distance. Use of a 3-ft (1-m) to 5-ft (1.5-m) riser pipe also is advised.

Some well points are manufactured to include a drive plate (Figure 10.29) so that the driving force is directed at the point; however not all drive points are created to withstand driving from the bottom, so it is important to confirm the specifications when ordering the points from the manufacturer. Driving a point from inside a casing is recommended for points longer than 5 ft (1.5 m); but attempting this procedure without having a drive plate in place can cause severe damage to the bottom of the screen.

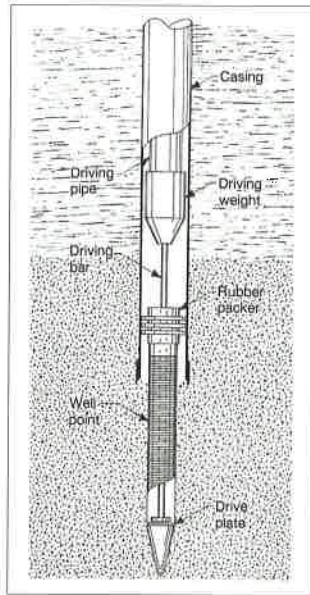

Figure 10.29. A driving bar can be used to drive well points inside the casing.

Pull-Back Installation Method

The pull-back installation method reduces problems such as setting the screen at the wrong depth, the heaving of sediment, and the sloughing of borehole walls caused by swelling clays or low hydrostatic pressure within the borehole. The pull-back procedure enables screen removal and replacement without disturbing the casing seal, and the cost (of pulling, cleaning, or replacing) usually is small as compared to the cost of drilling a new well.

The pull-back installation procedure is particularly suited for rotary rigs that can drill and drive casing, and for cable tool drilling rigs. This method involves installing casing to the total depth, telescoping the screen inside to full depth, and then extracting (pulling back) the casing far enough to expose the screen to the water-bearing formation (Figure 10.30). The casing must be strong enough to be set to full depth and then be pulled back the entire length of the screen.

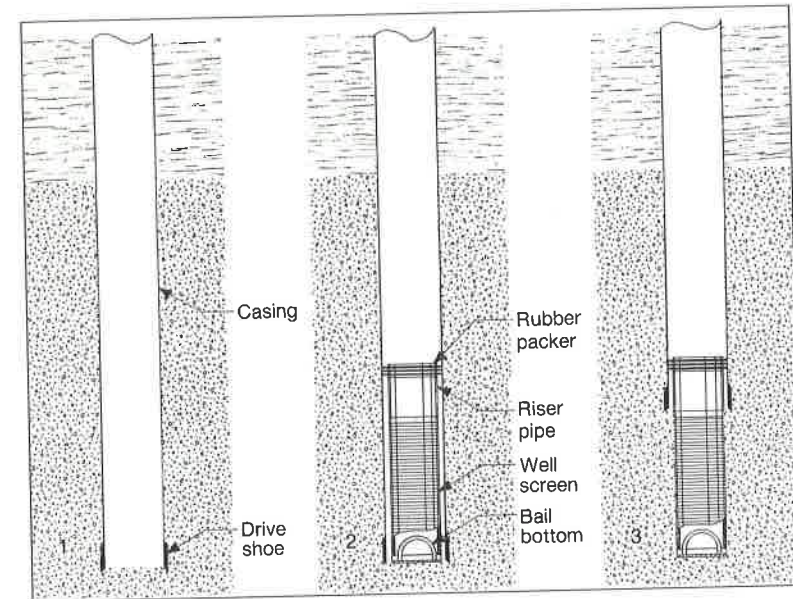

Figure 10.30. Basic operations in setting a well screen using the pull-back method: (1) driving, bailing, or lowering the casing to the full depth of the well; (2) lowering the screen inside the casing; and (3) pulling the casing back to expose the screen to the aquifer.

Telescope-size screens are available to be set using this method, and their dimensions allow them to be slipped inside standard pipes of the same diameter. Telescope sizes enable installation of the largest-diameter screen possible for a given casing diameter. Pipe-size screens (one or more diameters smaller than the casing) also are telescoped through larger-diameter casing.

It is good practice to attach riser pipe to the top of the screen. The riser pipe prevents screen damage during placement, and allows open screen area to be used opposite the formation—not up inside the casing. Recommended riser lengths are listed below.

- ♦ Domestic wells: 2 ft (0.6 m) to 5 ft (1.5 m)
- ♦ Larger-diameter deeper wells: 10 ft (3 m) to 20 ft (6.1 m)
- ♦ Small-diameter wells: 5 ft (1.5 m) to 10 ft (3 m) (helps prevent the casing from unintentionally being pulled back so quickly that the screen is disconnected beneath it)

Controlling sediment movement into the bottom of the casing is important, particularly if the screen has several slot sizes corresponding to individual sediment layers, or has blank sections between screen zones. If sediment heaving is a problem, keep the casing filled with water or a prepared drilling fluid to control fluid loss. If necessary, confining pressure can be controlled by weighting the drilling fluid. Sudden vertical movement of tools—especially bailers—increases the likelihood of heaving problems by reducing the bottom-hole pressure.

After sediment carefully is removed from the casing, the drilling professional must determine whether the casing can be withdrawn. If it cannot, then the drive shoe is removed (using an inside casing cutter) to reduce resistance, and the casing is pulled back a few inches. The screen then is lowered to the bottom of the well. Several means can be used to lower the screen, including: bail and hook, eccentric clevis (offset latch), casing lugs, J-hook, backoff sub, and wash-down bottoms (Figure 10.31).

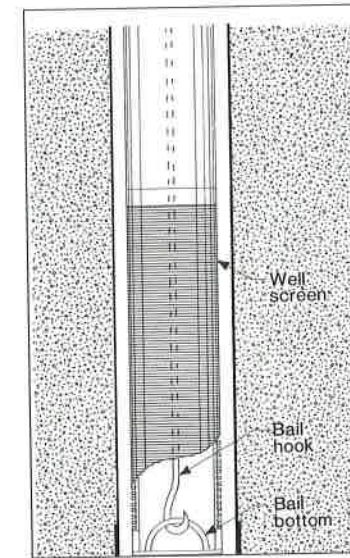

Figure 10.31. Screen is lowered by attaching the sand line to the bail bottom using a bail hook.

The drill string or a weight on the sand line is set on the plate-bottom of the screen, providing sufficient resistance to hold the screen during pull-back. The weight's line tension verifies the position of the screen while pulling. Without weighting, any heaving that occurs forces the screen upward at about the same rate that the casing is pulled. Alternatively, the screen can be placed in the bottom of the well, with the drill string set on top of the screen and the casing jacked back.

The casing can be pulled directly with the casing line by jarring it with the drilling string and bumper block (a timber wrapped with wire mesh or other retaining medium located below the crown that acts as a cushion in the event that the block is raised too far); by hydraulically jacking the string with a pull-ring gripping the casing; or (for long casing strings) by using a vibratory hammer to overcome skin friction between the casing and the formation.

As the screen is exposed, depth measurements to the screen should be taken. If no riser is attached to the screen, then the casing should be pulled back so that the packer is about 12 in (30.5 cm) above the bottom of the casing. The screen can be fully exposed beneath the casing if a riser pipe is attached.

FILTER PACKING WELLS

Many wells are designed to use an artificial filter pack. A filter-packed well has a predetermined thickness, whereas a naturally developed well has a graded permeable zone that is produced by the development process. Both types, when properly constructed, are efficient and stable. Filter-pack thickness has a direct impact on effective development at the formation-pack interface. The optimal thickness for a pack is 3 in (76 mm), and packs thicker than 5 in (127 mm) are not recommended because the effectiveness of the development procedures is impaired severely. Installing a filter pack that is less than 2 in (50 mm) thick is preferred, but is not practical.

All filter-pack materials and equipment should be treated with bactericide—usually sodium or calcium hypochlorite—and all water used in the filter-pack operation should be treated with 50 mg/ℓ free-chlorine solution before use. When possible, the drilling fluid should be thinned and be relatively free of solids before placement.

The grain sizes within filter-pack material should not segregate during placement. Dissimilar-sized particles fall through water at different velocities, thus well-sorted material (limited size distributions) is less apt to segregate during placement.

Tremie Pipe

Using a tremie pipe minimizes the tendency for particle separation and bridging when installing packs with high uniformity coefficients. Pipe that is 2 in (51 mm) or larger works in shallow to moderately deep wells (1,000 ft (305 m) to 1,500 ft (457 m)) when gravity-fed at approximately 1 ft³ (0.03 m³) of pack material per 5 gal (19 ℓ) to 10 gal (38 ℓ) of water. In deeper wells, filter pack should be pumped through a tremie pipe, which typically is placed before the screen and casing. The tremie pipe is raised periodically as the filter material builds up around the well screen, and also can be used to feel the top of the filter pack (or a weighted line can be inserted through the tremie).

Telltale Screen

Another filter-pack placement method incorporates use of a short telltale screen that is installed above the production screen (*see* Figure 10.32). Filter pack material is pumped into the annulus, and water flows into the screen and back to the surface through the drillpipe. The top of the casing must be sealed to the drillpipe so that the steadily increasing pressure can be monitored as the screen is covered. Surface pumping stops when an abrupt pressure spike occurs, which indicates that the telltale screen is covered. Suspended filter pack still falls, however the depth to the top of the pack can be calculated using the filter-pack volume in suspension and the water volume in the annular space.

Reverse Circulation

Packing large-diameter wells by using reverse circulation often is performed in a manner similar to packing a telltale screen. The borehole is kept full of fluid and pack material is carried downward outside the inner casing and screen. Sometimes a stinger pipe and dual-swab tool (with a perforated pipe between two rubber swabs) that forces water to the bottom of the screen before returning to the surface is used (this is particularly advantageous for use with long strings or unstable boreholes where use of a tremie pipe is not practical) (Figure 10.32).

Direct Circulation

Direct circulation of clean water can reduce bridging problems, and is an option to consider if pack material is contaminated by organic material (e.g., leaves, grass) or contains too many fines. The low uphole velocity allows gravity settlement, but still is ample to float organic material or fine sediment to the surface and thereby reduce development time. During circulation, make sure to avoid removing the filter cake and causing the borehole to become unstable.

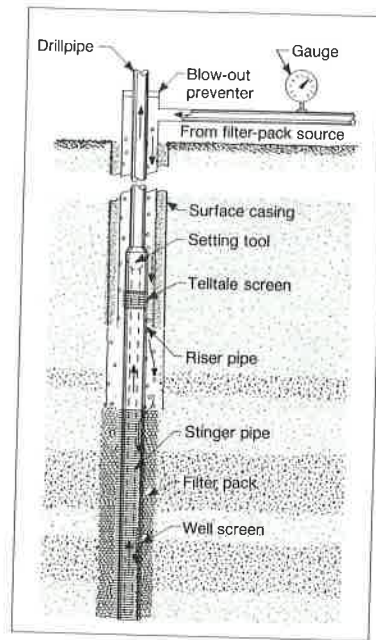

Figure 10.32. When filter packing a long screen, a stinger pipe is installed to force water to flow to the bottom of the screen.

A more complicated direct-circulation method used in small-diameter deep wells is pumping through a crossover tool. The crossover tool generally is used for a deep water well that has a small annulus. Figure 10.33 shows the basic features and flow paths during placement of the filter pack. The crossover tool is connected between the drillpipe and the top of the riser pipe. The top of the riser pipe can be sealed to the casing with a suitable packer (e.g., K-packer) after the filter pack is placed.

The stinger pipe extends to within 3 ft (0.9 m) of the bottom of the screen. The pumping pressure will increase suddenly when the filter pack material reaches the top of the screen. The upper portion of the sand injection pipe (above the crossover sub) is equipped with a left-threaded backoff sub, so it can be removed after sand installation. Careful observation is necessary and the procedure requires elaborate equipment and considerable skill. The operation must be coordinated to insure continuous flow at a rate that will not plug the drillpipe or cause a bridge to form in the borehole.

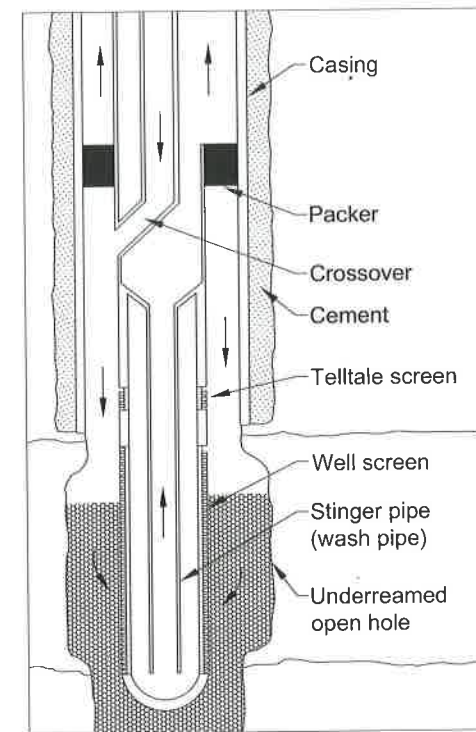

Figure 10.33. Diagram of essential features of crossover tool (Suman et al. 1983).

Filter-Pack Procedure for Telescoping Well Completion

Filter packing a telescoping well completion typically requires that an outer casing first be set to full depth. The inner casing and screen then are installed using centering guides, and the filter pack is placed (usually in stages) in the annular space around the screen—extending high enough above the screen to accommodate settlement as the outer casing is pulled back (Figure 10.34). The filter pack should extend above the top of the screen about one-fourth of the total screen length.

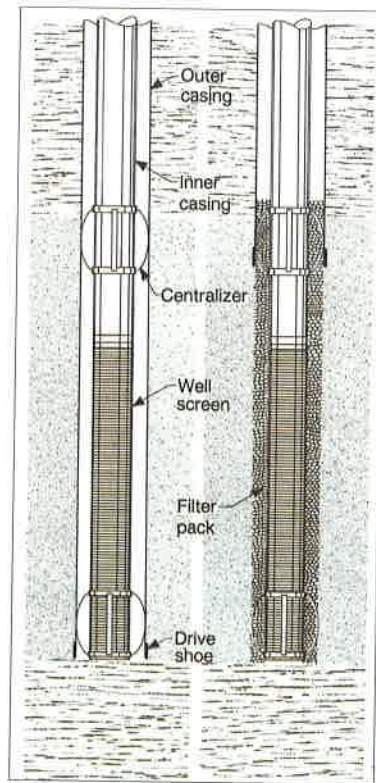

Figure 10.34. Illustration of inner-casing method. Screen assembly is centered in a cased borehole, and the outer casing is pulled back as filter pack is placed.

The depth to the top of the filter pack is monitored carefully so that it never drops below the bottom of the outer casing. A pack height of 5 ft (1.5 m) should be maintained above the screen during withdrawal. To prevent bridging, screen sections often are developed as casing is withdrawn. Overfilling the annulus during withdrawal can lead to sand locking of the outer casing to the screen.

As development proceeds, settlement occurs and more filter pack must be added to keep the top of the filter pack above the screen. Permanent filter-pack tubes sometimes are installed to allow gravel pack to be added to a well after completion if settling occurs (e.g., subsidence, pack quality, acid treatments). These tubes are not necessary if the filter pack is sealed using bentonite pellets or cement grout. The outer (surface) casing can be either removed or left in place.

Filter-Pack Procedure for Single-String Well Completion

In most rotary-drilled wells the screen and casing are placed as a single string (Figure 10.35). Centralizers generally are attached every 20 ft (6.1 m) on the screen body and every 40 ft (12.2 m) on the casing. The drilling rig holds the assembly in tension at the surface while the drilling-fluid viscosity is reduced as much as possible without allowing collapse of the wellbore. Breaking down the drilling fluid reduces development time, minimizes flotation effects, and increases the settlement rate for pack materials.

Downward drag forces on the screen and casing assembly during filter packing are noticeable, especially in larger-diameter deep wells. Finer pack materials exert more drag than do coarser materials, in part due to larger surface-area contact. Forces in excess of 20,000 lb (9,072 kg) have been recorded during filter packing. These dynamic loads should be factored into any deep-string assembly calculations to prevent casing or screen failure.

Filter-pack materials usually extend some distance above the top of the screen, and pack material should be added as required during development. After development and backfilling of the borehole, tension forces on the casing and screen are released.

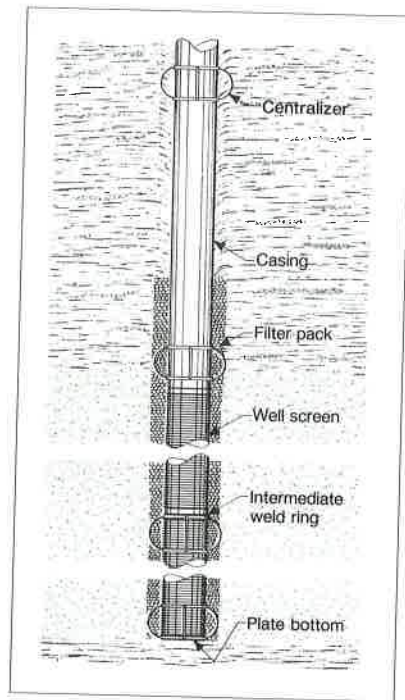

Figure 10.35. A screen and casing can be placed into the borehole as a unit.

REMOVING WELL SCREEN

Screens generally are not removed. Some reasons for removing a screen assembly include incorrect placement; deepening (after some years of use); corrosion damage; well abandonment; and reuse of the recovered screen in another well. Telescoped screens typically are considerably easier to remove than are those placed by other methods. Screens that have been in place for a long time usually are fixed firmly in the formation.

Regardless of the type of screen, to remove it safely the pulling force should be distributed over a considerable portion of the screen length. Light acid treatment helps loosen the screen by dissolving some of the surface incrustation, thus reducing the force needed to pull the screen (see Chapter 13 for discussion

of acid-treatment procedures). Injecting NuWell[®] 400, a surfactant, flocculates sediments around the screen, helping to minimize the force required to remove a screen.

Certain mechanical procedures, such as a washover pipe (see the Glossary for a definition) in underreamed holes, can be used to loosen the surrounding filter pack if the necessary clearance is available. In conventional filter-packed wells, the plate bottom is milled out and bailing or air-lifting is used to remove as much of the pack as possible. A loosened screen can be removed by using an overshot tool (see the Glossary for a definition) or various types of spears (see the Glossary for a definition), however spears can damage screen. Importantly, never attempt to pull on a bail bottom unless the screen has just been set and is held only loosely by the sediment.

Screens that are 4 in (102 mm) in diameter (and larger) are best removed using a pipe of smaller diameter that is sand locked inside the screen and which transmits the pulling force to the well screen. Angular sand placed between the pulling pipe and screen becomes locked when lift is applied to the pulling pipe (Figure 10.36).

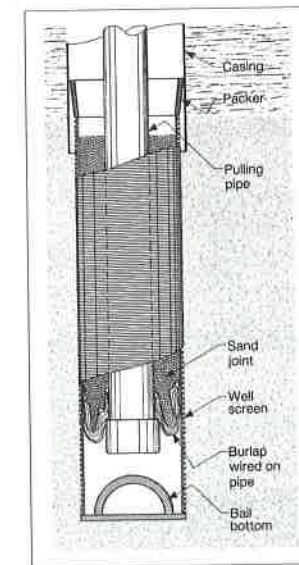

Figure 10.36. Diagram of sand-locking method of removing well screens.

Two or three slots can be cut in the pulling pipe just above the burlap (Figure 10.36), so that the sand joint can be loosened from inside if the below-ground connection must be broken. Slots also can be cut in the pulling pipe, level to the upper part of the screen, so that excess sand runs into the pipe and to prevent overfilling the screen (which could sand lock the drill string). If sand locking occurs then, to disengage the drill string, install right- and left-hand couplings between the bottom of the drill pipe and the pulling pipe. The screen and part of the pulling pipe then remain in the ground. Sometimes attaching weld rings at two or three different levels on the pulling pipe helps evenly distribute sand friction. A series of pipe nipples joined by pipe couplings is especially practical for pulling 6-in (152-mm) diameter (and smaller) screens.

Alternately, if the screen is equipped with a sump pipe then the pulling force can be concentrated there. An elliptical plate that has been cut in half and hinged together folds when lowered and, when lifted, unfolds and locks in the sump pipe. The folding plate should not be so large that it causes bulging of the sump pipe, which could lead to interlocking of the sump-pipe casing.

Table 10.7. Sizes of Pulling Pipe

| Size of Telescope Screen | | Inside Diameter of Screen | | Size of Pulling Pipe | | Quantity of Sand | |
|--------------------------|-----|---------------------------|-----|----------------------|-----|---------------------|-------------------|
| in | mm | in | mm | in | mm | ft ³ /ft | m ³ /m |
| 4 | 102 | 3 | 76 | 1½ | 38 | 0.031 | 0.003 |
| 5 | 127 | 4 | 102 | 2 | 51 | 0.056 | 0.005 |
| 6 | 152 | 4⅞ | 124 | 3 | 76 | 0.070 | 0.006 |
| 8 | 203 | 6⅞ | 168 | 4 | 102 | 0.134 | 0.012 |
| 10 | 254 | 8⅞ | 219 | 5 | 127 | 0.254 | 0.024 |
| 10 | 254 | 8⅞ | 219 | 6 | 152 | 0.187 | 0.017 |
| 12 | 305 | 10⅞ | 264 | 6 | 152 | 0.361 | 0.034 |
| 16 | 406 | 13⅞ | 333 | 8 | 203 | 0.535 | 0.050 |
| 16 | 406 | 13⅞ | 333 | 10 | 254 | 0.308 | 0.029 |
| 18 | 457 | 15 | 381 | 10 | 254 | 0.602 | 0.056 |
| 20 | 508 | 17 | 432 | 12 | 305 | 0.695 | 0.065 |
| 24 | 610 | 21 | 533 | 12 | 305 | 1.52 | 0.142 |

WELL PLUMBNESS AND ALIGNMENT

Water wells should be both straight and plumb, although—in practice—any borehole of substantial depth is not perfectly straight or perfectly plumb. A well is straight when each casing section connects while maintaining perfect alignment. A borehole is plumb when its center does not deviate from the (theoretical) vertical line that runs from the earth's surface to its center (Figure 10.37). A wellbore sometimes can be straight but not plumb; but if it is plumb then it must be straight.

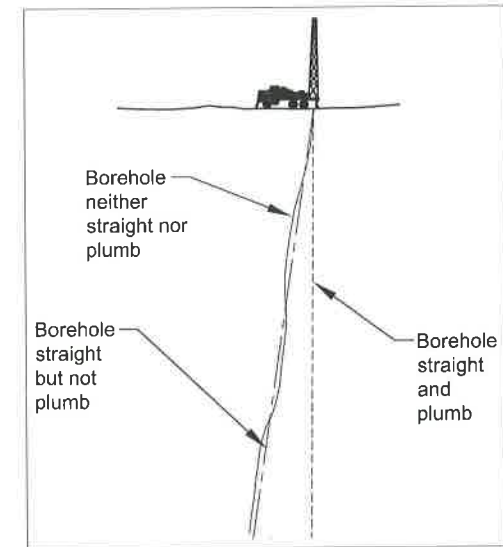

Figure 10.37. A borehole should be both straight and plumb.

Some tolerance in straightness (alignment) and plumbness normally is allowable. Typically, a deviation from plumb of two-thirds the inside diameter per 100 ft (30.5 m) of anticipated pump setting is allowed and is reasonable (American Water Works Association 2006). The AWWA Standard A100 is reasonable for casing diameters larger than 12 in (30.5 cm), but for smaller casing diameters this standard might be too stringent. Table 10.8 shows the allowable limits of deviation for various depths.

Table 10.8. Well-Deflection Limits for Drift-Indicator Survey

| Depth | | Allowable Deviation | |
|-------|------|---------------------|-----|
| ft | m | ft | m |
| 50 | 15.2 | 0.4 | 0.1 |
| 100 | 30.5 | 0.9 | 0.3 |
| 150 | 45.7 | 1.3 | 0.4 |
| 200 | 61 | 1.7 | 0.5 |
| 250 | 76.2 | 2.2 | 0.7 |
| 300 | 91.5 | 2.6 | 0.8 |
| 400 | 122 | 3.5 | 1.1 |
| 450 | 137 | 3.9 | 1.2 |
| 500 | 152 | 4.4 | 1.3 |
| 600 | 183 | 5.2 | 1.6 |
| 700 | 213 | 6.1 | 1.9 |
| 800 | 244 | 7 | 2.1 |
| 900 | 274 | 7.8 | 2.4 |
| 1,000 | 305 | 8.7 | 2.7 |
| 1,100 | 335 | 9.6 | 2.9 |
| 1,200 | 366 | 10.5 | 3.2 |
| 1,300 | 396 | 11.3 | 3.4 |
| 1,400 | 427 | 12.2 | 3.7 |
| 1,500 | 457 | 13.1 | 4 |
| 1,600 | 488 | 14 | 4.3 |
| 1,700 | 518 | 14.8 | 4.5 |
| 1,800 | 549 | 15.7 | 4.8 |
| 1,900 | 579 | 16.6 | 5.1 |
| 2,000 | 610 | 17.4 | 5.3 |
| 2,100 | 640 | 18.3 | 5.6 |
| 2,200 | 671 | 19.2 | 5.9 |
| 2,300 | 701 | 20.1 | 6.1 |
| 2,400 | 732 | 20.9 | 6.4 |
| 2,500 | 762 | 21.8 | 6.6 |

Straightness of the wellbore is most important when a vertical turbine pump is being considered for use. If alignment deviates beyond a certain limit, then the pump cannot be set. A pump can be installed in a well that is straight but

which is not plumb; however too much vertical deviation affects the operation and life of some pumps. In general, turbine pumps require a reasonably straight wellbore, whereas submersible pumps can be set in wellbores that are somewhat misaligned.

Conditions that can cause a borehole to be misaligned and out of plumb include the following.

- ◆ Character of the subsurface material (faults, boulders in the borehole, dipping strata)
- ◆ Placement of too much or too little weight on the drill bit when drilling
- ◆ Trueness of the casing and drillpipe
- ◆ Pull-down force applied to the top of the drillpipe during rotary drilling (as opposed to weight on the bit that is derived strictly from drill-collar weight)

Gravity tends to make a drill bit cut a vertical hole, but varying hardness of formations encountered deflects a bit from following a truly vertical course. The edge of a boulder can deflect a cable tool, rotary bit, or even a well casing that is being driven, thus causing drift. Too much force applied atop a rotating drill stem bends the slender column of drillpipe causing an off-center cut. Heavy drill collars (located just above the bit) concentrate weight at the bit, tending to overcome drift from true vertical. Collars are more rigid than ordinary drillpipe and stiffen the lower part of the drill string. Large stabilizers also are used to help drill straight holes.

Sections of casing can be slightly bowed, for example, or a joint's center line might not coincide exactly with the casing's center line. Commercial tolerances permit some deviation in straightness and the accuracy of threads, and these must be considered when specifying the allowable deviation of a completed well.

Borehole alignment should be checked several times when drilling a deep well, especially when using the cable-tool drilling method. Immediately correcting any misalignment that is discovered saves both time and money. The alignment often is checked at predetermined intervals with an inclinometer survey tool during rotary drilling (e.g., 100 ft (30.5 m), 500 ft (152 m), 1,000 ft (305 m)). In many cases, however, the alignment is checked only after the well has been completed.

Special deviation instruments are available to measure misalignment. A magnetic or gyroscopic deviation survey commonly is recorded along with standard geophysical logs. Special centralizers keep the instrument centered, and readings (given directly as displacement) are transmitted to the surface. Chapter 4 contains additional information on alignment loss.

UNDERGROUND "PITLESS" DISCHARGE

A sanitary, practical underground discharge is accomplished using either a pitless unit or a pitless adaptor. This device is connected to the well casing below ground level through a hole cut into the side of the well casing (Figure 10.38, Figure 10.39). A pitless unit is installed by first cutting off the casing below ground and then welding the spool-unit directly to the casing. The unit extends above ground level and provides a watertight subsurface connection for buried pump discharge or suction lines. To prevent freezing, the pipes must be buried below the frost line. Additional information on pitless adaptors is contained in Appendix 10.B (DVD).

In some cases, the entire water system is located in or near the well. A buried pressure tank provides cooler water, eliminates moisture condensation, and does not take up space in the house (Figure 10.39).

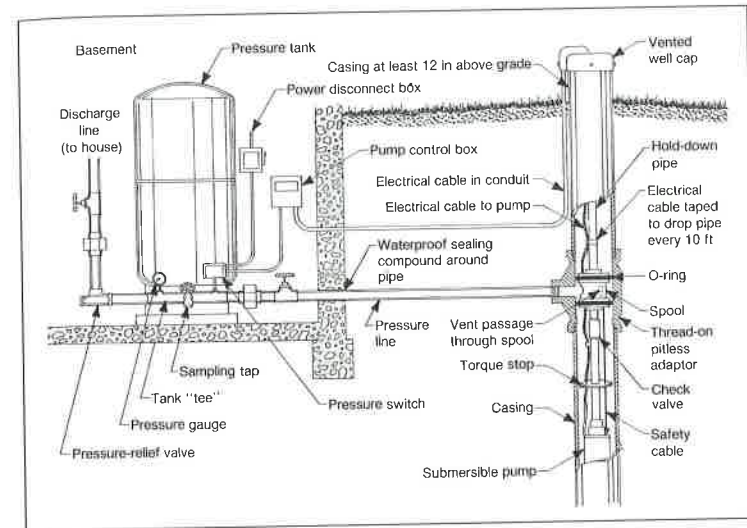

Figure 10.38. Diagram of a typical domestic-well pitless installation equipped with a submersible pump.

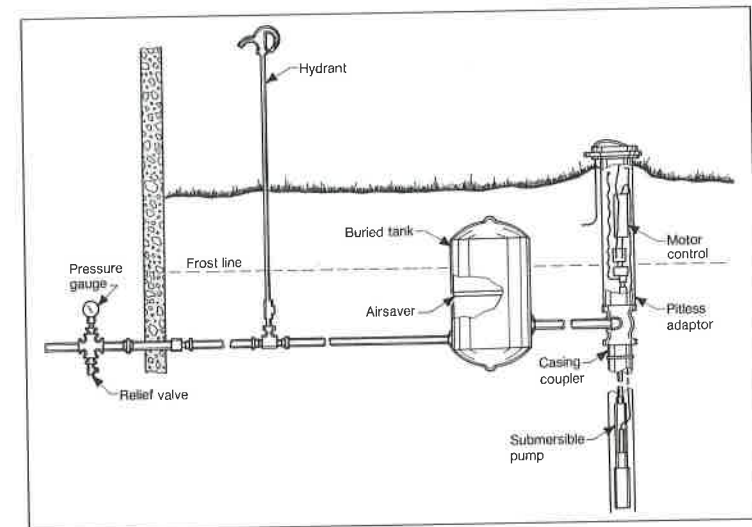

Figure 10.39. Diagram of a pitless adaptor connected to underground pressure tank.